

结构特点 Design features

- 内装、单端面、单弹簧、非平衡型、传动套传动结构，任意旋向，结构紧凑，安装方便。
- Internally mounted, single face, single spring, unbalanced structure and driven by brace ear and claw transmission, any rotation direction, it can be mounted conveniently.

材料 Materials(to DIN24960)

- 旋转环 Rotary Ring: U12、U22
- 静止环 Stationary Ring: A、B、U12、U22
- 辅助密封 Auxiliary Seal: V、T1
- 弹簧及其他结构件材料 Spring and Other Parts: F、G

适用范围 Operating limits

- 压力 Pressure: $\leq 0.8\text{MPa}$
- 温度 Temperature: $-20\sim 200^{\circ}\text{C}$
- 线速度 Speeds: $\leq 13\text{m/sec}$
- 粘度 Viscosity: $\leq 1.0\text{Pa}\cdot\text{s}(1000\text{cp})$ 软对硬(Soft VS Hard)
 $\leq 3.5\text{Pa}\cdot\text{s}(3500\text{cp})$ 硬对硬(Hard VS Hard)

用途 Applications

用于石油化工、炼油、制药、造纸、给排水、污水处理等工业的泵类等类似的旋转轴密封。
Used in all types of rotating equipment, pumps, to suit industries such as oil refining, petrochemical, pharmaceutical, pulp and paper, and waste water treatment.

介质 Medium

油类、水及其它弱腐蚀性溶液。
Oil, water and other weak corrosive fluid.

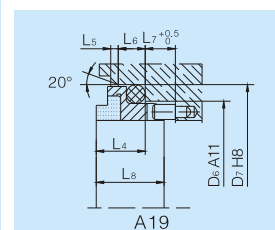
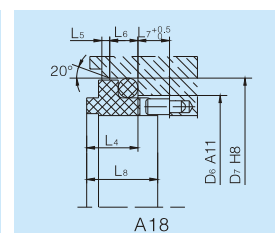
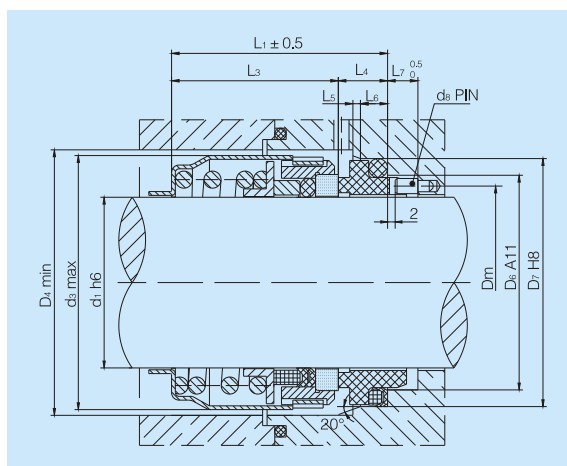

型号 Model	d1	d3	D4	D6	D7	dm	d8	L1	L3	L4	L5	L6	L7	L8
CN Gx-16	16	33	36	25	33	21	2	36.5	24.5	12	1.5	5.5	7	16
CN Gx-18	18	35	38	28	36	23	2	37.5	25.5	12	1.5	5.5	7	16
CN Gx-20	20	37	40	30	40	25	3	40.5	26.5	14	2.0	6.5	8	19
CN Gx-22	22	39	42	32	42	27	3	42.5	28.5	14	2.0	6.5	8	19
CN Gx-25	25	42	45	35	45	30	3	42.5	28.5	14	2.0	6.5	8	19
CN Gx-28	28	45	48	38	48	33	3	45.5	31.5	14	2.0	6.5	8	19
CN Gx-30	30	52	55	40	50	35	3	49.0	35.0	14	2.0	6.5	8	19
CN Gx-35	35	57	60	45	55	40	3	51.0	37.0	14	2.0	6.5	8	19
CN Gx-40	40	62	65	50	60	45	3	54.0	40.0	14	2.0	6.5	8	19
CN Gx-45	45	67	70	55	65	50	3	59.0	45.0	14	2.0	6.5	8	19
CN Gx-50	50	72	75	60	70	55	3	62.0	48.0	14	2.5	6.5	8	19
CN Gx-55	55	77	80	65	75	60	3	64.0	50.0	14	2.5	6.5	8	19
CN Gx-60	60	82	85	70	80	65	3	64.0	50.0	14	2.5	6.5	8	19
CN Gx-65	65	92	95	80	90	73	3	72.0	55.0	17	2.5	6.5	8	22
CN Gx-70	70	97	100	85	97	78	3	76.0	57.0	19	2.5	7.5	9	25
CN Gx-75	75	102	105	90	102	83	3	76.0	57.0	19	2.5	7.5	9	25
CN Gx-80	80	107	110	95	107	88	3	81.0	62.0	19	3.0	7.5	9	25
CN Gx-85	85	112	115	100	112	93	3	81.0	62.0	19	3.0	7.5	9	25
CN Gx-90	90	117	120	105	117	98	3	82.0	63.0	19	3.0	7.5	9	25
CN Gx-95	95	122	125	110	122	103	3	82.0	63.0	19	3.0	7.5	9	25
CN Gx-100	100	127	130	115	127	108	3	82.0	63.0	19	3.0	7.5	9	25